

# AX Series

Programmable Controller

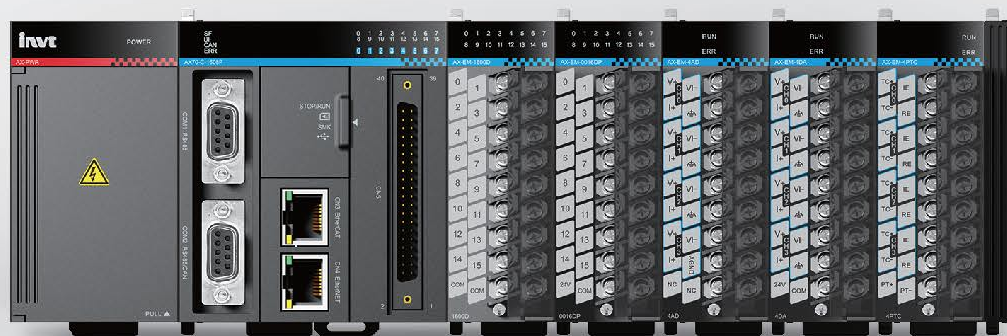

CE

**invt**

# CONTENTS >>

Making collaboration between human and machine more **simple** and **effective**



■ EtherCAT open network

■ Advanced motion control

■ Large-scale distributed I/O

A large, white industrial robot arm is the central focus of the image. It is shown in a close-up, slightly angled view, highlighting its joints and cables. The background is a blurred industrial setting with other machinery and bright lighting. The overall color palette is dominated by light blues and whites, with a touch of orange from a glowing component in the lower-left foreground.

# AX series programmable controllers

---

Product Features .....	3
Technical Data .....	13
Main Dimensions .....	16
Ordering Data .....	17
Automation Product Family .....	19
Marketing Service Network .....	20

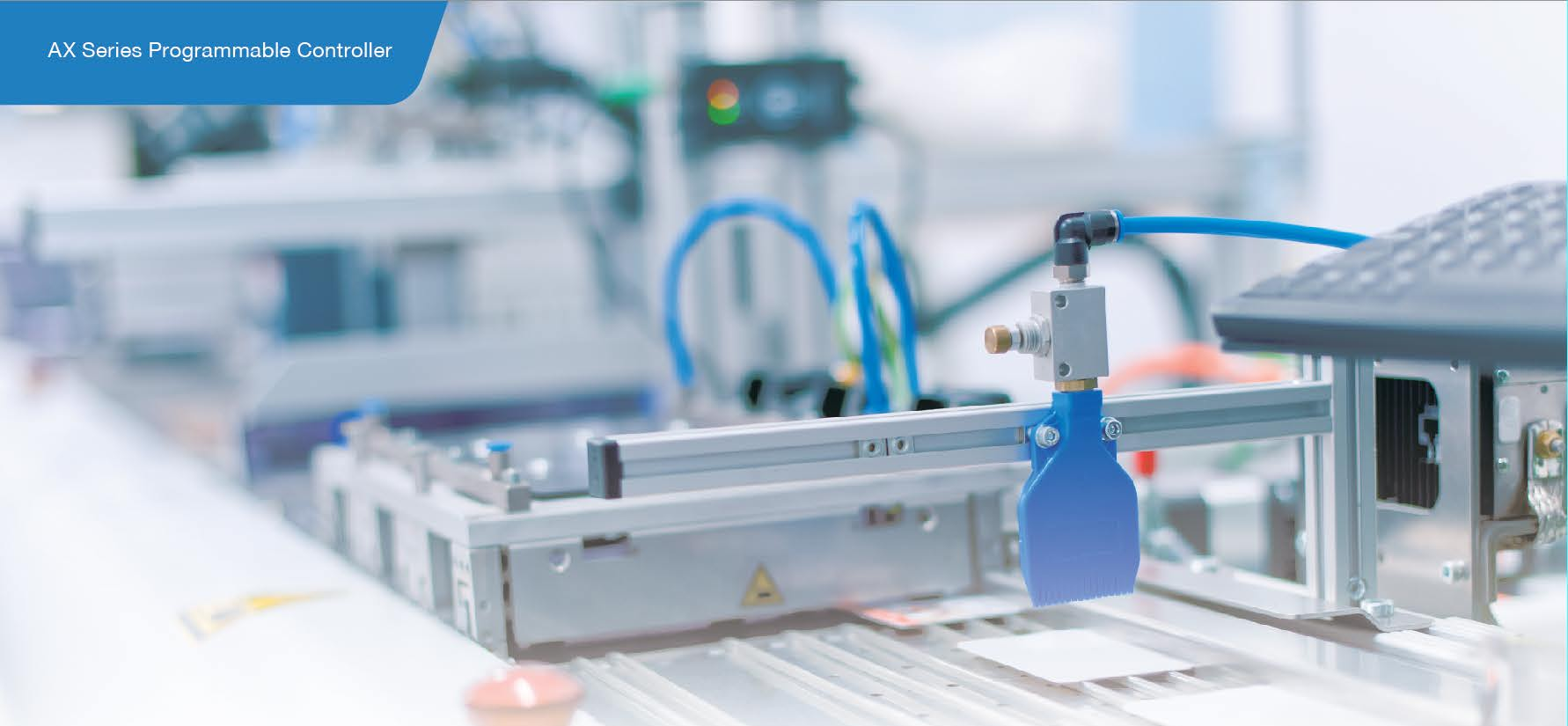

# Product Features

AX series programmable controllers are a family of INVT high-performance general-purpose controllers for medium and large control systems. With advanced embedded functions and rich scalability, the product can provide best automated control systems by integrating with diversified motion control communication buses and connecting to drive devices, so as to improve production efficiency and quality, and reduce development and maintenance costs.

## High-speed calculation capability >>

- Uses the CPU with the basic command processing speed up to 1ns.

Execution time on bits	- 1ns
Execution time on words	- 4ns
Calculation time on fixed-point numbers	80ns
Calculation time on floating-point numbers	150ns

## Large-scale distributed expansion >>

- Supports EtherCAT distributed expansion.

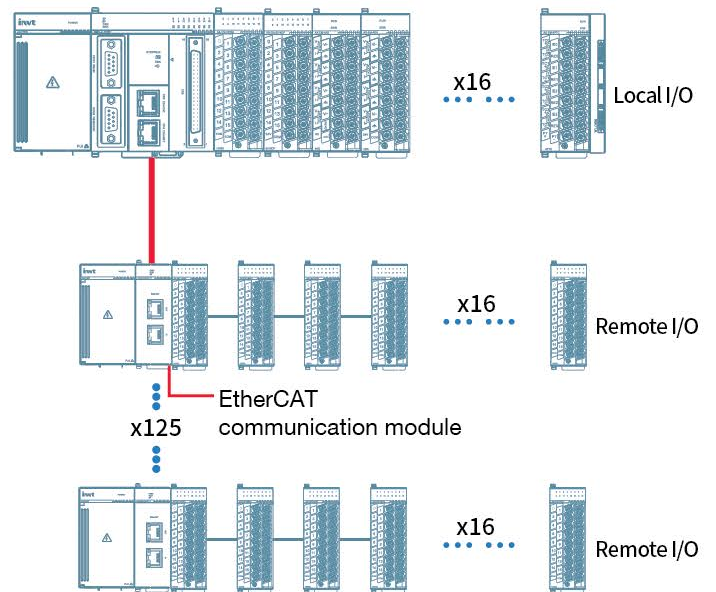

## Advanced motion control >>

Integrated with rich motion control functions; Implements synchronization control and advanced motion control such as electronic cam, electronic gear, and positioning by using high-speed EtherCAT bus or pulses.

## Electronic cam/gear >>

### Processing quintic polynomial cam curve tracks

- Obtains continuous trajectories and smooth motion trajectories by specifying the speed, position and acceleration boundary conditions.

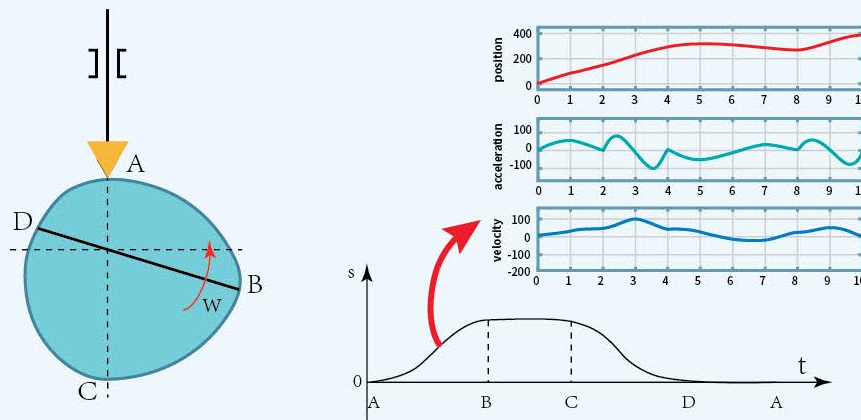

### Cam curves online modifying

- No need to regenerate cam curves, since position compensation can be made for motion track points with deviations.

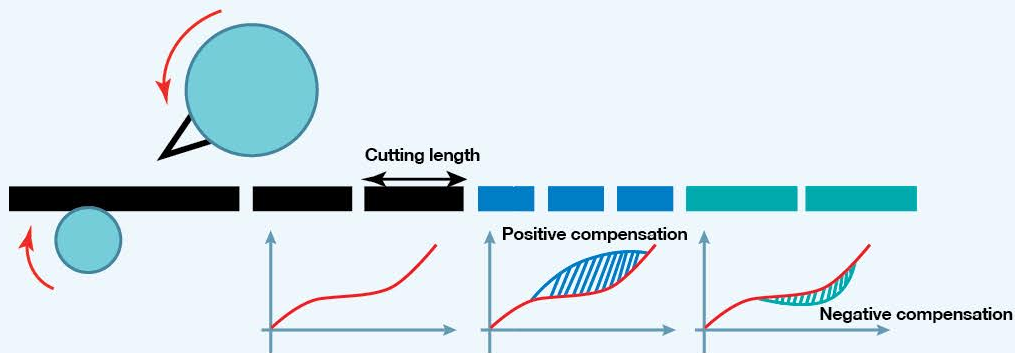

### Real- and virtual-axis control mode

- Uses virtual axes to simplify mechanical structure, improve accuracy and response speed, and achieve the linkage, collaboration, and coherence of multi-axis motion.

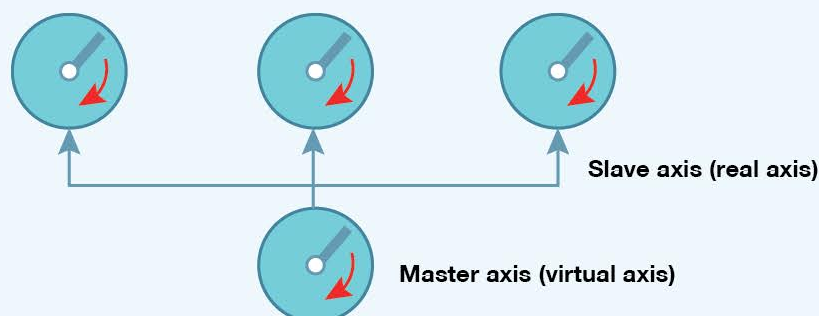

### Flying shear

- Achieves fixed- and variable-length cutting on materials by tracking feeding speed, setting cutting lengths or tracking color mark positions, and automatically planning movement trajectory.

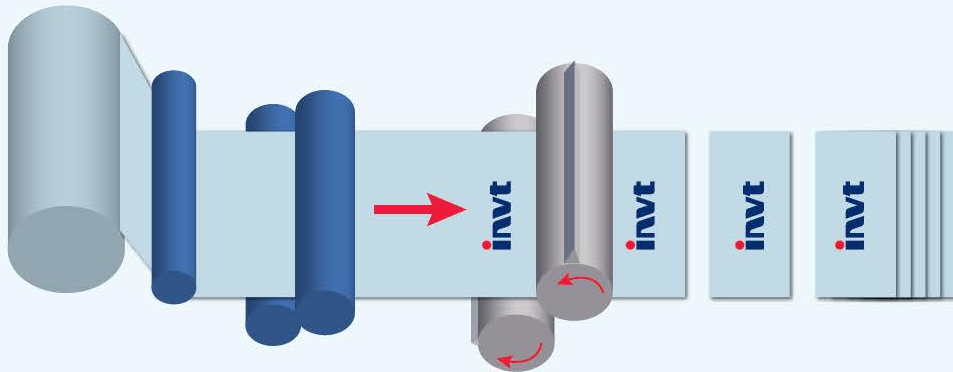

### Chasing shear

- Achieves synchronous cutting and quick return by setting the starting points and lengths of synchronization zones, determining the allowable traverse ranges of the shearing axis and the starting and end points of reciprocating motion, and planning cam track curves.

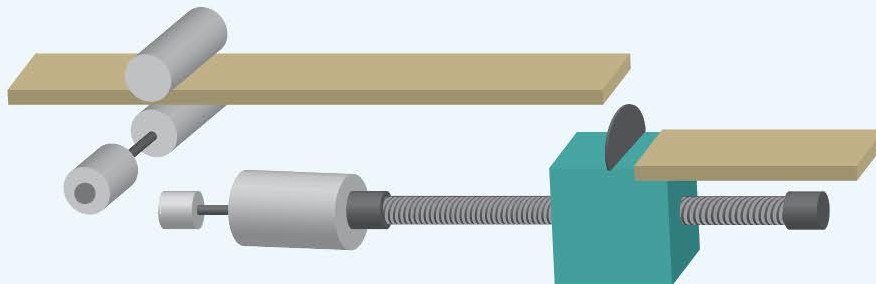

### Color mark detection

- Obtains the actual servo motor position by receiving mark signal; and achieves fixed-position cutting on materials by compensating for the cutter axis offset during position obtaining.

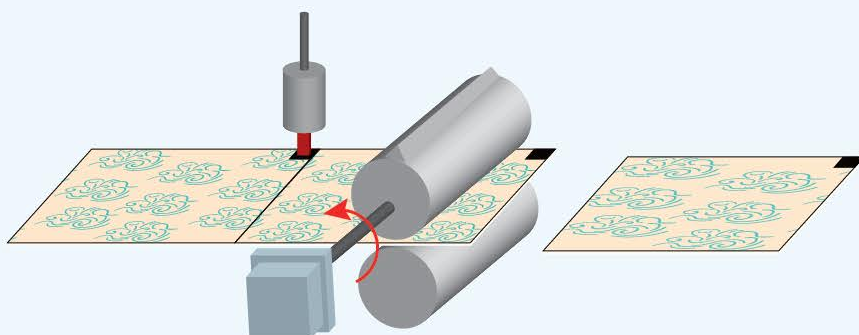

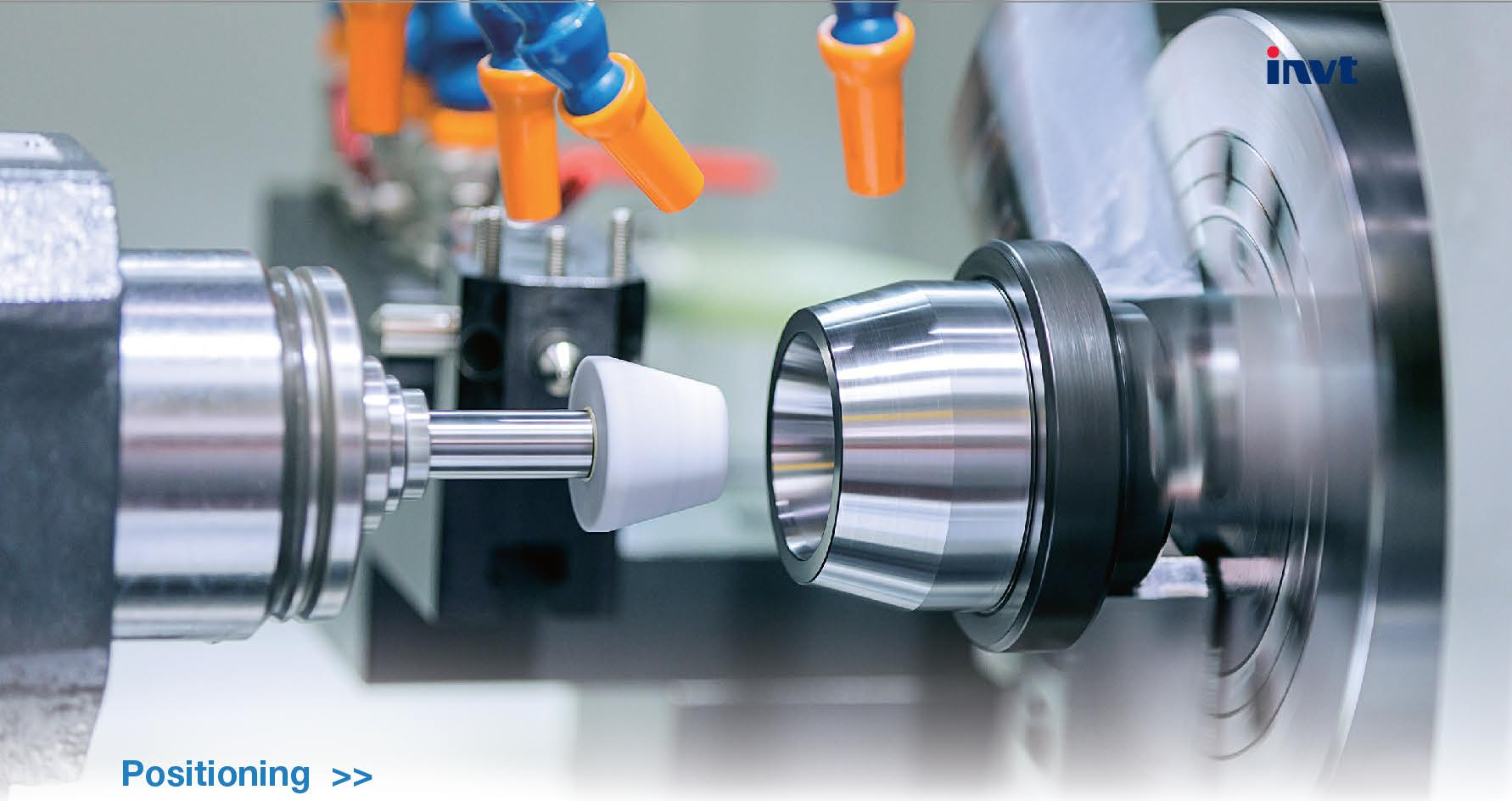

## Positioning >>

Supports 200k pulses/s, including pulses with direction, forward/reverse pulses and quadrature pulses, to implement position and speed control.

### Single axis control

- Includes manual, jog, homing, PTP and speed control modes.

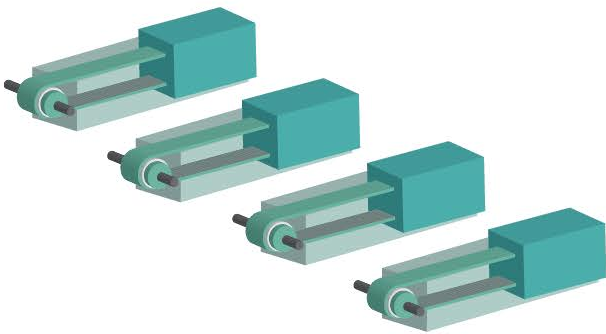

### Multi-axes interpolation

- Allows axes 2, 3, and 4 to execute simultaneous linear motion; and supports running at relative and absolute positions.

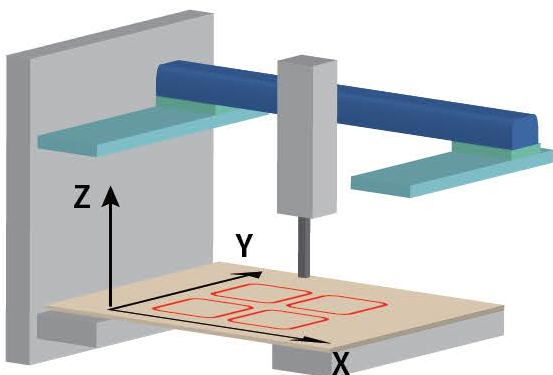

### Arc interpolation

- Supports arc interpolation for any two axes on planes XY/XZ/YZ using the trigonometric function interpolation method; and supports multi-axis linear interpolation with trajectory distortion controlled within 0.001mm.

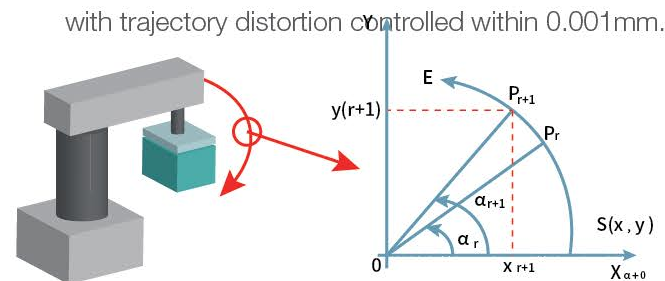

### Diverse ACC/DEC processing

- Pre ACC/DEC control on T- and S-type curves

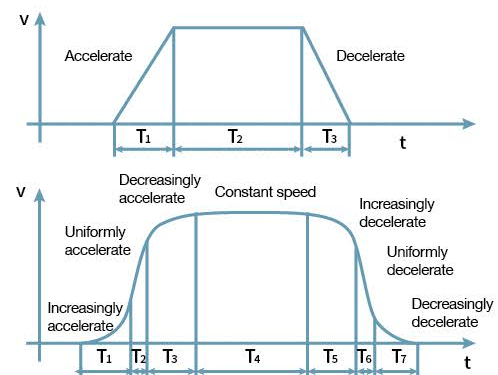

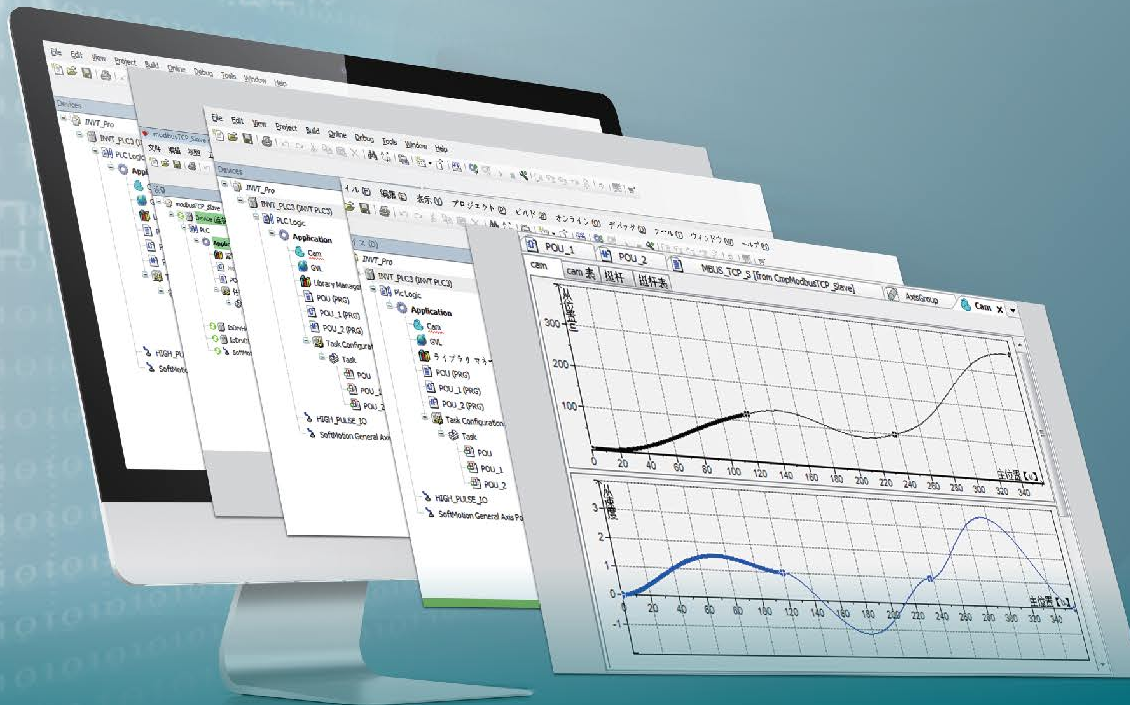

# Visual configuration >>

## Graphical configuration interface

### Configuration programming

- Supports the programming language system compliant with C61131-3 standards.
- Supports the six programming languages compliant with PLCopen standards.
- Supports programming methods including programs, functions, and function blocks, reducing programming time.
- Easy to achieve complex motion control for the use of high-level programming languages.

### Highly effective debugging

- Uses the LAN or USB interface to perform online debugging and offline simulation.
  - Online debugging: Online program modifying and single-step running, improving debugging efficiency.
  - Offline simulation: In case of no servo axis connection, virtual axes are added to perform simulated debugging on programs, making debugging flexible.

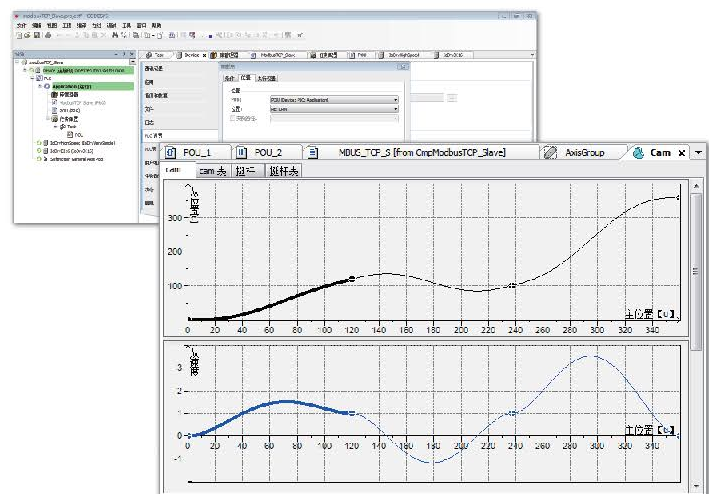
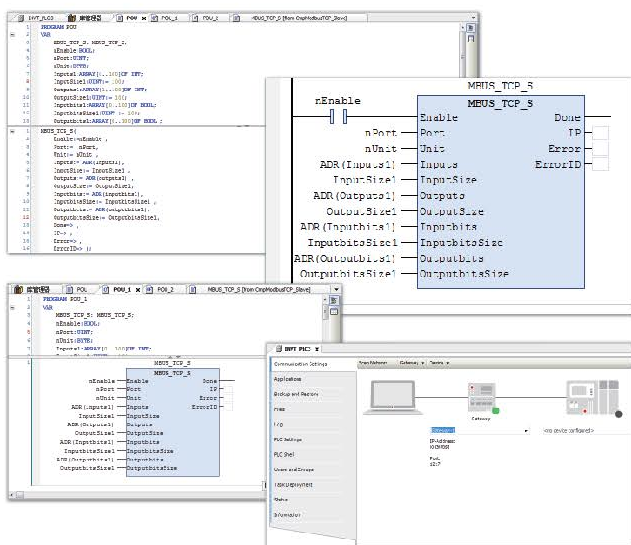



## Safe and easy to use >>

### Compatible with thermal resistors and thermocouples

- The temperature module supports both thermal resistors and thermocouples.
- Supports 4-wired thermal resistors without external power supply.

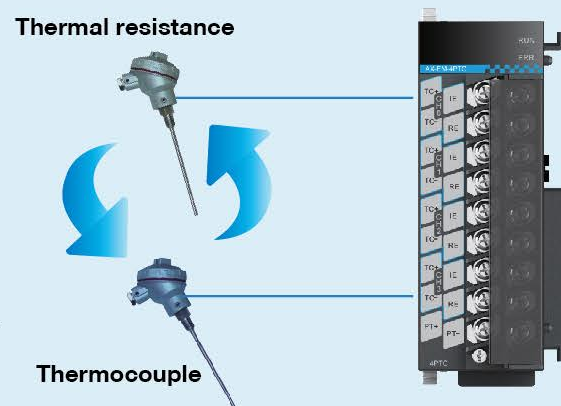

### Permanent storage of data

- At power failure, data is automatically saved to the FLASH memory, without the use of a backup battery.



	At controller power-off
PLC program zone	Permanently saved
Power-failure protection zone	Permanently saved

### Security

- Multi-level security password and user permission management.
- Encrypted communication between the development system and controller, protecting automation equipment with data exchange from unauthorized access.
- Disabled program upload function which is used to protect users' intellectual property rights.

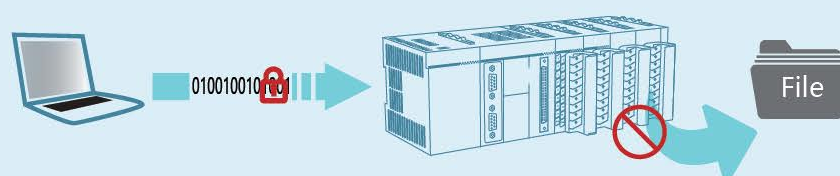





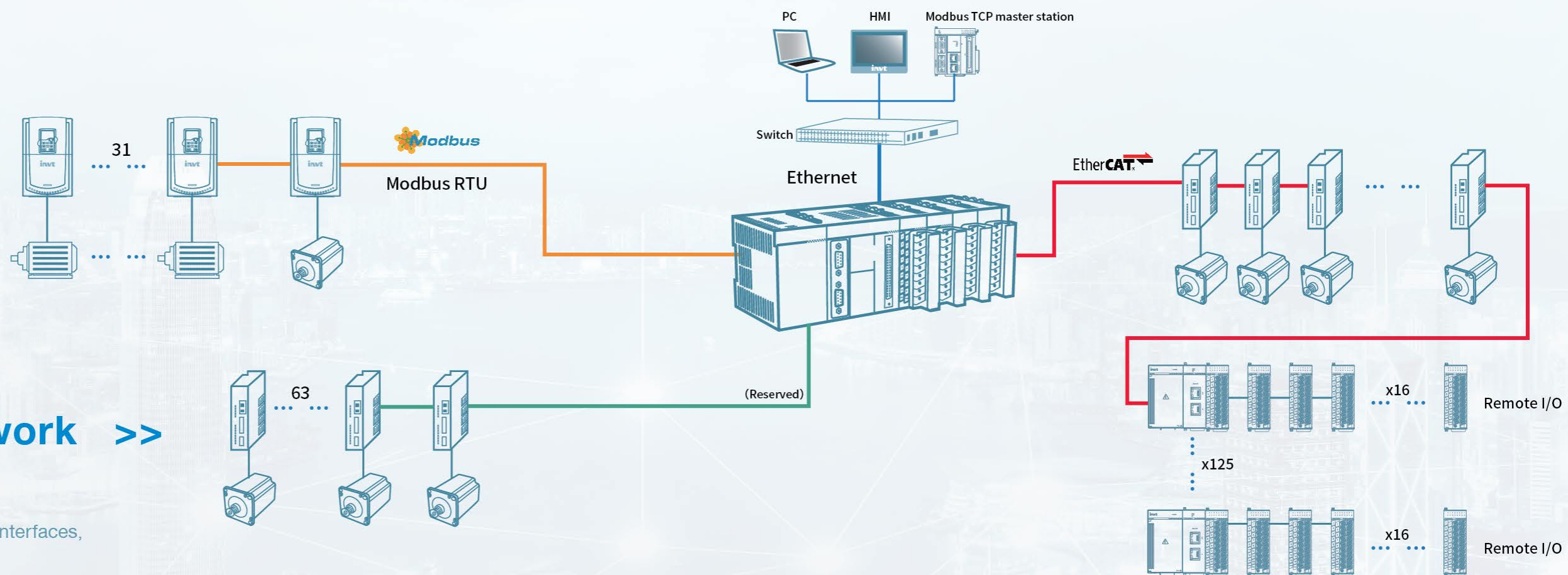

## Multi-layer open network >>

Supports diverse communication and expansion interfaces, meeting various communication needs.

### EtherCAT bus

- The CPU module supports 32 servo axes.
- Supports the expansion up to 125 slave EtherCAT modules.
- Supports the simultaneous expansion of both servo axis and racks.
- Fieldbus communication rate up to 100Mbps, with the max. distance between two nodes up to 100m.

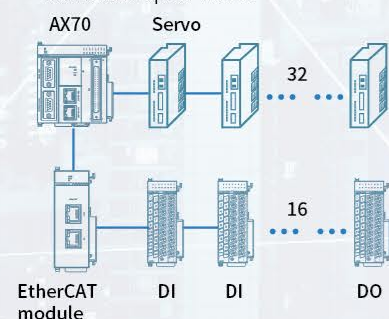

### RS485 serial interface

- Two-channel independent serial interface.
- Supports Modbus RTU master/slave station.
- Supports the access from 31 slave devices when serving as the Modbus RTU primary node.

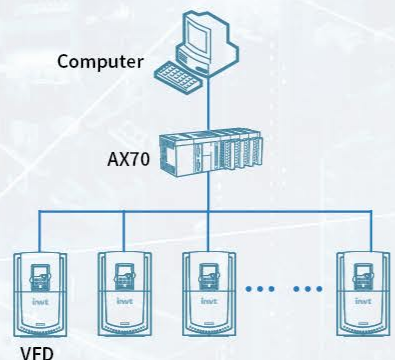

### USB and SD card slots

- Mini USB interface, supporting program update and online debugging.
- Supports 32GB Micro SD card for data recording and program update.

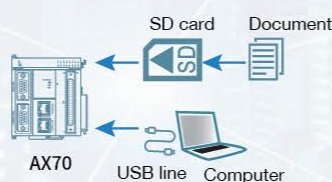

### LAN interface

- Supports Modbus TCP slave station.
- Supports the simultaneous communication with 16 master stations when serving as a Modbus TCP slave station.
- Supports the access from 63 slave stations when serving as the Modbus TCP master station.

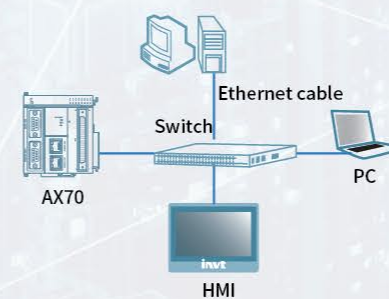

### Local high-speed I/O

- 16 channels of high-speed input and 8 channels of high-speed output, supporting 4-axis pulse motion control.
- 8 channels of 200kHz single phase or AB phase high-speed pulse counting.
- 6 channels of differential or single end input.
- 8 channels can be externally high speed interrupted.

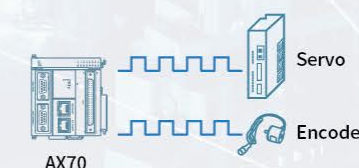

### Local bus

- Supports 16 digital I/O modules, with the refresh time from the beginning to the end less than 8ms.
- Supports 8 analog I/O modules, with the refresh time from the beginning to the end less than 8ms.

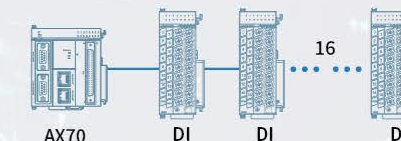

## CPU module

Model		AX70-C-1608P	AX71-C-1608P
Rated working voltage		DC24V(-5%~+5%)	DC24V(-5%~+5%)
Memory			
Program capacity	Size	10M Word	10M Word
	Qty	POU definitions: 3000 POU instances: 6000	POU definitions: 3000 POU instances: 6000
Data capacity		8M Word	8M Word
Capacity of data saved at power failure		512K Byte	512K Byte
Max. capacity of expanded SD card		32G	32G
I/O			
High-speed I/O		16 high-speed inputs and 8 high-speed outputs	16 high-speed inputs and 8 high-speed outputs
Max. number of local expansion modules		16	16
Max. number of I/O points	Local	256	256
	EtherCAT bus	32000	16000
High-speed input		Supporting 8 channels of 200kHz single phase or A/B phase high-speed pulse counting, in which A/B phase supports frequency multiplication by 1, 2, and 4. Supporting 6 channels of differential input or single end input.	Supporting 8 channels of 200kHz single phase or A/B phase high-speed pulse counting, in which A/B phase supports frequency multiplication by 1, 2, and 4. Supporting 6 channels of differential input or single end input.
High-speed output		8 channels of 200kHz high-speed output, supporting 4-axis pulse motion control.	8 channels of 200kHz high-speed output, supporting 4-axis pulse motion control.
Support for I/O interruption		8 channels of high-speed interrupt input.	8 channels of high-speed interrupt input.
Interrupt response time		250us	250us
Communication network and interface			
Ethernet		RJ45*1, 10/100Base-TX, supporting PLC software download, Modbus TCP, and TCP/IP protocols	
EtherCAT		RJ45*1, 100Base-TX, with the distance between two slave nodes less than 100m	
CANopen		DB9F*1 (COM2, sharing the interface with RS485)	
Serial communication (RS485)		DB9F*2, supporting Modbus RTU primary and secondary nodes	
USB		Mini USB*1, for PC communication, program download and debugging	
Storage card		Micro SD*1, for system update	
Inter-PLC connection		Ethernet/Modbus RTU	
Upper computer connection		Ethernet/Modbus/CANopen	
Modem connection		Supported	
Command period			
Execution time on bits		1ns	
Execution time on words		4ns	
Execution time on fixed-point numbers		80ns	
Execution time on floating-point numbers		150ns	
Motion control			
Number of control axes	Max. number of control axes	32	8
Point-to-point (PTP) motion	Manual functions	●	●
	Homing	●	●
	Point locating	●	●
	Speed control	●	●
	Speed variation (reserved)	●	●
	Emergency stop	●	●
	Halt (reserved)	●	●
	Reset	●	●
	Position superposition	●	●
	Magnification variation (reserved)	●	●
	Time and position control (reserved)	●	●
	Time and speed control (reserved)	●	●
	Interpolation motion	Linear interpolation	4 axes, 200kHz, in three modes: pulse + direction, FWD/REV pulse sequence, and quadrature encoder pulse
Plane arc interpolation		2 axes, 200kHz, in three modes: pulse + direction, FWD/REV pulse sequence, and quadrature encoder pulse	—
Axis group (reserved)	Multi-group linear interpolation (bus)	●	—
	Multi-group plane arc interpolation (bus)	●	—
	Single- and multi-axis hybrid control (bus)	●	—

Note: The symbol ● indicates supported; the symbol — indicates not supported.

Motion control			
Electronic cam (e-cam)	Max. number of e-cam tables	64	64
	Max. point number in all e-cam tables	4194240	4194240
	Max. point number in one e-cam table	65535	65535
	TP compensation	64 groups	64 groups
Electronic gear (e-gear)	●		●
Motion control period	EtherCAT data communication is the same in control period; 1ms of pulse communication period		EtherCAT data communication is the same in control period; 1ms of pulse communication period
Position unit	Pulses, millimeter (mm), inch (in.)		Pulses, millimeter (mm), inch (in.)
Clock			
Internal clock	At environment temperature of 55 °C, error range: -3.5 – +0.5 min/month At environment temperature of 25 °C, error range: -1.5 – +1.5 min/month At environment temperature of 0 °C, error range: -3 – +1 min/month		
Configuration programming			
Programming platform	Invntmatic Studio		
Programming languages	IL、ST、FBD、LD、CFC、SFC		
Basic specifications			
Running environment temperature	-10~55 °C		
Running environment humidity	10%~95% (no condensation)		
Storage temperature	-40~70 °C		
Storage environment humidity	10%~100%, with condensation		
Ingress protection rating	IP20		
Running environment	No corrosive gas		
Altitude	2000m or lower		
Installation manner	In control cabinet		
Pollution degree	Degree 2 or lower, compliant with IEC 61131-2		
Surge	2kV		
Anti-interference	2kV voltage-withstand power cable (compliant with IEC 61000-4-4)		
ESD class	6kV CD or 8kV AD		
Vibration resistant	5~8.5Hz, vibration amplitude of 3.5mm; 8.5~150Hz, acceleration of 10m/s <sup>2</sup> ; X/Y/Z axis, 10cycles		
Dimensions and weight			
W x H x D (mm)	80*90*95mm		
Weight	0.38kg		

## Power supply module

Model	AX-PWR
Input power exception	AC100~240V(-15%~+10%)
Input frequency	50/60Hz(-5%~+5%)
Output voltage	DC24V(-5%~+5%)
Rated output current	2A
Efficiency	>70%
Overcurrent protection	Supported
Fuse	Built in
Dimensions (W x H x D)	32x90x117mm

## Digital input module

Model	AX-EM-1600D
Number of channels	16
Input type	Source/sink
Input voltage	DC 24V (up to 30V)
Input current	4.7mA
Port filter time	10ms
Isolation method	Optocoupler
Dimensions (W x H x D)	32x90x117mm

## Digital output module

Model	AX-EM-0016DP
Number of channels	16
Output type	PNP transistor (of the source type) output, active high
Power supply voltage	DC24V
Output voltage	12V~24V(-15%~+5%)
Max. load	0.5A/point; 2A/common terminal (resistive load)
Isolation method	Magnetic
Short-circuit protection output	Supported (max. current limited to 1.7A when protection enabled)
Dimensions (W x H x D)	32x90x117mm

## Digital output module

Model	AX-EM-0016DN
Number of channels	16
Output type	NPN transistor (of the sink type) output, active low
Power supply voltage	DC24V
Output voltage	12V~24V(-15%~+5%)
Max. load	0.5A/point; 2A/common terminal (resistive load)
Isolation method	Magnetic
Short-circuit protection output	Supported (max. current limited to 1.4A when protection enabled)
Dimensions (W x H x D)	32x90x117mm

## Analog input module

Model	AX-EM-4AD
Number of channels	4
Voltage range	±5V, ±10V, +5V, +10V
Current range	0~20mA, 4~20mA, ±20mA
Accuracy in room temperature (of 25°C)	Voltage ± 0.1%; current ± 0.1%
Resolution	24 bits
Disconnection detection	Supported
Limit voltage	± 12V
Limit current	± 24mA
Isolation method	Isolated between I/O port and power supply Not isolated between channels
Dimensions (W x H x D)	32x90x117mm

## Analog output module

Model	AX-EM-4DA
Number of channels	4
Voltage range	±5V, ±10V, +5V, +10V
Current range	0~20mA, 4~20mA
Accuracy in room temperature (of 25°C)	Voltage ± 0.1%; current ± 0.1%
Resolution	16 bits
Disconnection detection	Supported
Isolation method	Isolated between I/O port and power supply Not isolated between channels
Dimensions (W x H x D)	32x90x117mm

## Communication module

Model	AX-EM-RCM-ET
Communication protocol	EtherCAT
Max. communication rate	100Mbps
Synchronization method	Distributed clocks for the servo; input and output synchronization for I/O
Physical layer	100BASE-TX
Baud rate	100Mbit/s (100BASE-TX)
Transmission distance	Less than 100m between two nodes
Number of slave nodes	1~125. The internal address is automatically allocated according to the network bus connection sequence.
Duplex mode	Full duplex
Topology structure	Linear
Transmission medium	Category-5 or higher twisted pair
Process data	Up to 1486 bytes contained in a single Ethernet frame
Refresh time	The refresh time of 1000 digital inputs and outputs is about 30μs, and that of 32 servo applications is about 100μs.
Dimensions (W x H x D)	32x90x95mm

## Temperature module

Model	AX-EM-4PTC
Number of channels	4
Wiring method	Two-, three-, or four-wire
Supported thermal resistors	PT100, PT500, PT1000, CU100
Supported thermocouples	Types B, E, J, K, N, R, S, and T
Accuracy in room temperature (of 25°C)	Thermal resistance: Full scale±0.3% Thermocouple: Full scale ±0.1%±1°C
Accuracy in working temperature	Thermal resistance: Full scale±1% Thermocouple: Full scale ±0.3%±1°C
Cold junction compensation method	Internal/external
Resolution	24 bits
Sensitivity	0.1°C/°F
Isolation method	Isolated between I/O port and power supply Not isolated between channels
Dimensions (W x H x D)	32x90x117mm

# Main Dimensions

## CPU

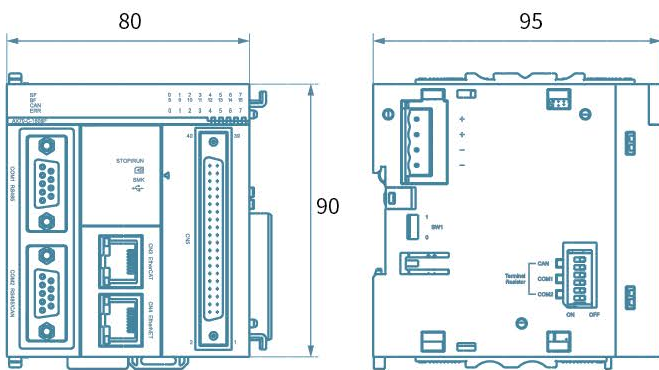

Unit: mm

## Power supply

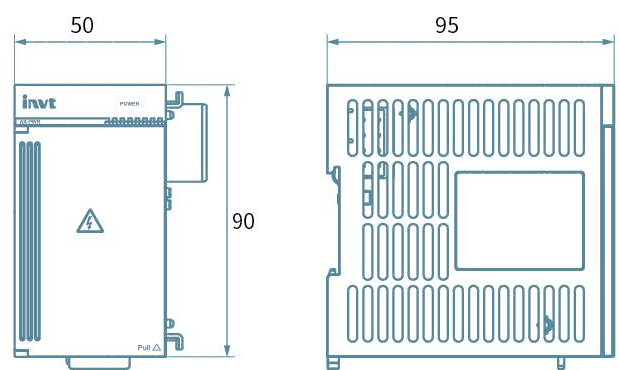

Unit: mm

## Extension module (Digital/Analog/Temperature)

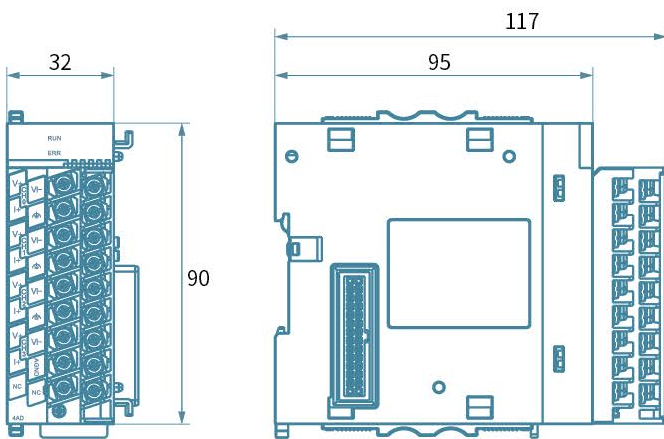

Unit: mm

## Communication module

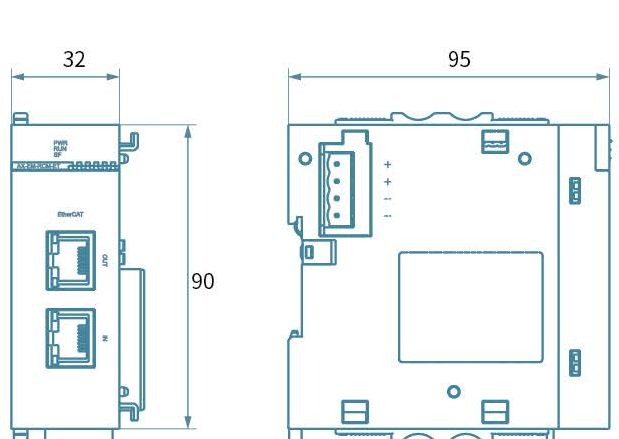

Unit: mm

## Tail-board

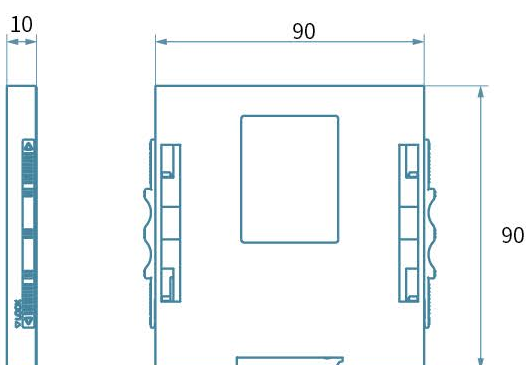

Unit: mm



# Ordering Data

Model	Description
<b>AX70-C-1608P</b>	CPU module; EtherCAT/CANopen/Ethernet, RS485*2, PNP transistor output; RoHS
<b>AX71-C-1608P</b>	CPU module; EtherCAT (8-axis)/CANopen/Ethernet, RS485*2, PNP transistor output; RoHS
<b>AX-PWR</b>	Power supply module; Input 100-240VAC 50Hz/60Hz; Output 2A, 24VDC; RoHS
<b>AX-EM-1600D</b>	Digital input module; 16 inputs, 24VDC, supporting the source and sink types; RoHS
<b>AX-EM-0016DP</b>	Digital output module; 16 PNP transistor outputs, max. current 500mA, 24VDC; RoHS
<b>AX-EM-0016DN</b>	Digital output module; 16 NPN transistor outputs, max. current 500mA, 24VDC; RoHS
<b>AX-EM-4AD</b>	Analog input module; 4 analog inputs, 24-bit resolution, room-temperature accuracy $\pm 0.1\%$ ; RoHS
<b>AX-EM-4DA</b>	Analog input module; 4 analog inputs, 16-bit resolution, room-temperature accuracy $\pm 0.1\%$ ; RoHS
<b>AX-EM-RCM-ET</b>	Communication module; EtherCAT slave-node module, supporting the expansion of 16 I/O modules; RoHS
<b>AX-EM-4PTC</b>	Temperature detection module; 4-channel thermal resistor & thermocouple temperature detection module, 24-bit resolution, sensitivity of 0.1°C/°F; RoHS Supported thermocouples: Types B, E, J, K, N, R, S, T Supported thermal resistors: PT100, PT500, PT1000, CU100

## Optional parts

Model	Description
<b>AX-HIO-40</b>	Signal processing module; 40-pin high-speed I/O adapter terminal block; RoHS
<b>AX-L1-10</b>	Data cable; High-speed I/O lead cable, L=1m; RoHS
<b>AX-L1-20</b>	Data cable; High-speed I/O lead cable, L=2m; RoHS
<b>AX-L2-10</b>	Data cable; RS485/CAN communication cable (DB9 male), L=1m; RoHS
<b>AX-L2-20</b>	Data cable; RS485/CAN communication cable (DB9 male), L=2m; RoHS
<b>AX-L2-50</b>	Data cable; RS485/CAN communication cable (DB9 male), L=5m; RoHS
<b>AX-L3-20</b>	Data cable; Category-5e shielded network cable, L=2m; RoHS
<b>AX-L3-50</b>	Data cable; Category-5e shielded network cable, L=5m; RoHS

# New impetus for modern industrial upgrading >>



## Easy to meet complex motion control requirements

- The product can help you to easily achieve positioning control, high synchronization control, and cam control by means of simple parameter setting and programming through the integrated high-speed EtherCAT bus and visual programming environment, which meets the real-time, high-speed, high-precision and personalized control needs, suitable for packaging, printing, lithium battery and other industries.



## High flexibility control solution to realize distributed control

- Forms a diverse and open industrial network, which improves the efficiency of technical personnel and adapts to the changing system expansion and project optimization requirements. Each controller can realize a single controller control solution, or multiple controllers can form a distributed control system, which can be widely used in industries such as multi-color printing and lithium battery.



## Large-scale I/O application

- Based on the EtherCAT bus, the distributed I/O system ensures the flexibility of data transmission systems and reliability of communication between the controller CPU and I/O. It is applicable to large-scale production lines with multi-process, multi-control points and rapid response application requirements, such as filling, packaging, labeling, and packaging, helping the automation transformation and upgrade of production lines and equipment.

# Automation Product Family



## ■ HMI

- VK Series
- VT Series
- VS Series



## ■ Controller

- VC Series All-in-one Machine
- IVC1S Series Programmable Controller
- IVC1L Series Programmable Controller
- IVC2L Series Programmable Controller
- IVC3 Series Programmable Controller
- AX Series High-performance Programmable Controller



## ■ Servo System

- General servo drive System
- Industry specific servo system
- Industry specific electronic control system



## ■ VFD

- Low-voltage general VFD
- Midum-voltage VFD
- Industry specific VFD

# Marketing Service Network

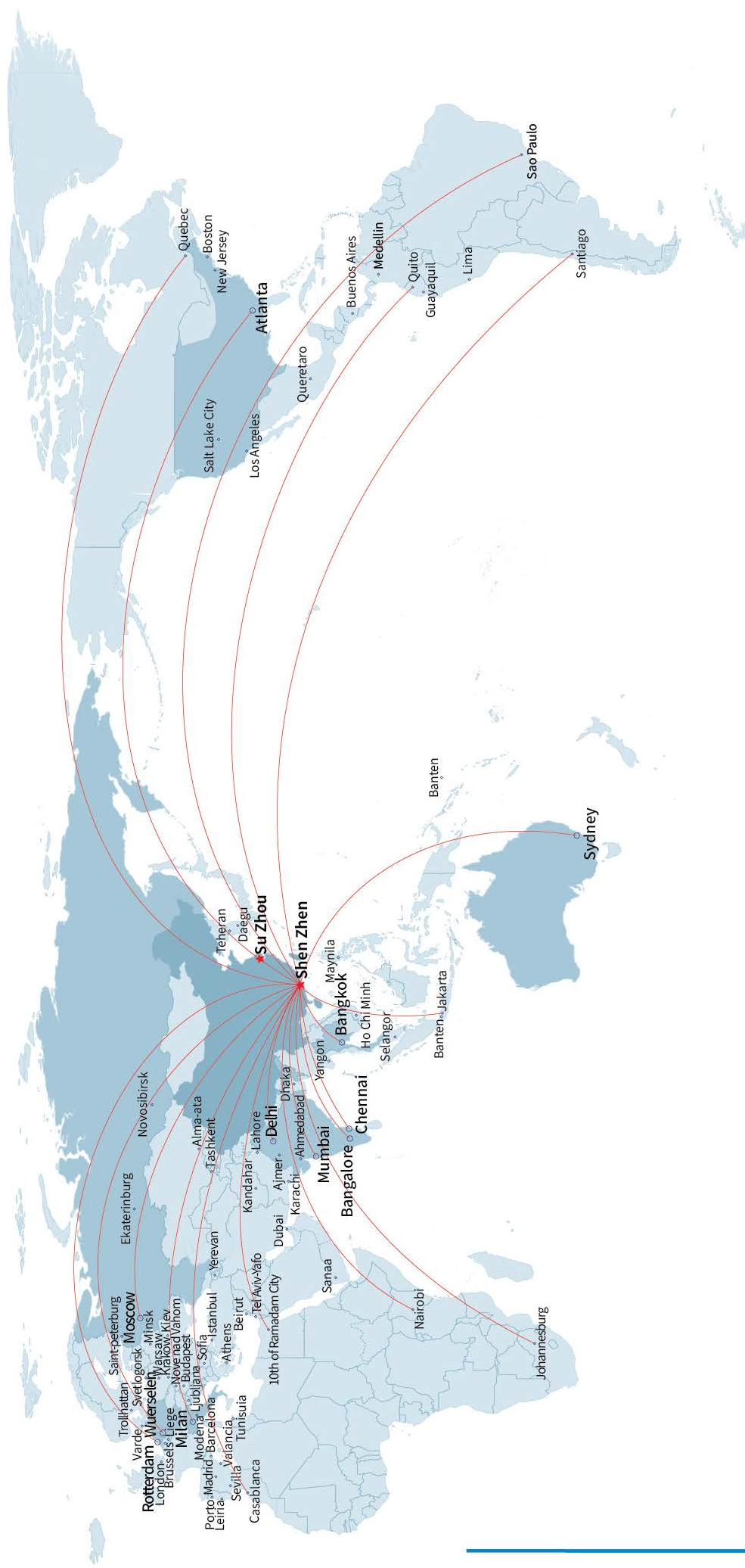

★ INVT Headquarters

INVT Office & Service in 11 countries

Sales and Service Partners in 68 countries

*Your trusted industry automation solution provider*

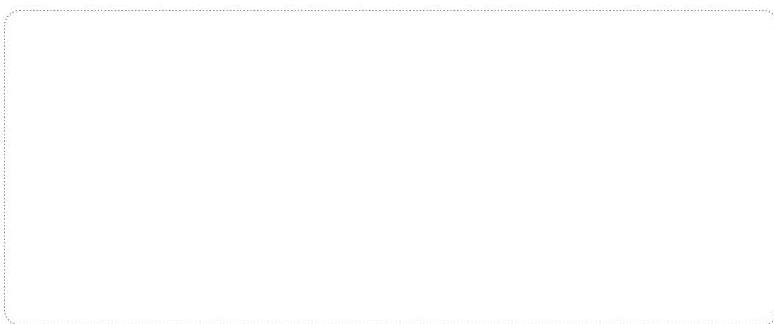

Service line:86-755-23535967 E-mail:overseas@invt.com.cn Website:www.invt.com

SHENZHEN INVT ELECTRIC CO.,LTD. INVT Guangming Technology Building, Songbai Road, Matian, Guangming District, Shenzhen, China

- |                               |  |                                       |                            |                                   |
|-------------------------------|--|---------------------------------------|----------------------------|-----------------------------------|
| <b>Industrial Automation:</b> | • Frequency AC Drive                         | • Servo & Motion Control              | • Motor & Electric Spindle | • PLC                             |
|                               | • HMI  | • Intelligent Elevator Control System | • Traction Drive           |                                   |
| <b>Electric Power:</b>        | • SVG  | • Solar Pump Controller               | • UPS                      | • Online Energy Management System |
|                               | • New Energy Vehicle Electric Control System |                                       |                            |                                   |

INVT Copyright.  
Information may be subject to change without notice during product improving.

66003-00216 20200901(V1.0)